

Pulsar® Model R80 80 GHz FMCW Radar Level Transmitter

DESCRIPTION

The Pulsar® Model R80 radar transmitter is the latest generation of Magnetrol® 24 VDC, loop-powered, non-contact radar transmitters. Utilizing Frequency Modulated Continuous Wave (FMCW) radar technology, this transmitter offers enhanced performance, proactive diagnostics, and various configuration wizards to bring simplicity to an often complex technology.

This latest entry into the radar level measurement field is designed to provide unparalleled performance and ease of use. The 80 GHz Pulsar Model R80 is the perfect complement to our 6 GHz Pulsar Model R96 and 26 GHz Model R86 radar transmitters. Together, this transmitter family, along with the acclaimed Model 706 GWR transmitter, offers the ultimate solution set for those difficult industrial process level applications.

TECHNOLOGY

The Pulsar Model R80 radar transmitter is based on FMCW radar technology. Transmitting a continuous signal with a constantly changing frequency down toward the liquid, the difference in the frequencies detected between the transmitted signal and return echoes is a function of the distance.

Liquid level is then calculated based on transmitter configuration.

APPLICATIONS

MEDIA: Liquids and slurries; hydrocarbons to water-based media (dielectric 1.4–100)

VESSELS: Most process or storage vessels up to rated temperature and pressure. Pits and sumps as well as glass-lined tanks.

CONDITIONS: Virtually all level measurement and control applications including those exhibiting varying dielectric, visible vapors, high fill/empty rates, turbulence, low to moderate foam and buildup.



FEATURES

- Multivariable two-wire, 24 VDC loop-powered transmitter for level, volume, or flow
- Performance not process dependent (changing specific gravity and dielectric have no effect)
- 80 GHz operating frequency offers superior performance, smaller antennas, better accuracy and enhanced resolution
- Antenna designs up to +200 °C (+400 °F), -1 to 70 bar (-14.5 to 1000 psi)
- Range up to 30 meters (100 feet)
- 4-button keypad and graphic LCD display allow for convenient viewing of configuration parameters and echo curve
- Proactive diagnostics advise not only what is wrong, but also offer troubleshooting tips
- SIL 2 suitable (92.3% SFF, with full FMEDA report available)
- PACTware™ PC Program and enhanced DTMs for advanced configuration and troubleshooting
- Available with HART® digital output

TECHNOLOGY

FREQUENCY MODULATED CONTINUOUS WAVE (FMCW) RADAR

The Pulsar R80 is a top-mounted, downward-facing FMCW radar transmitter operating at 80 GHz. Unlike previous Pulsar transmitters that emit short bursts of 26 GHz energy and measure the transit time of the signal reflected off the liquid surface, FMCW devices transmit a continuous signal with a constantly changing frequency down toward the liquid.

The detected difference in frequencies between the transmitted signal and return echo is a function of the distance. See Figure 1 at right. Level is then calculated by factoring in tank height and other configuration information.

FMCW captures its process variable information in the frequency domain, which supports more accurate signal

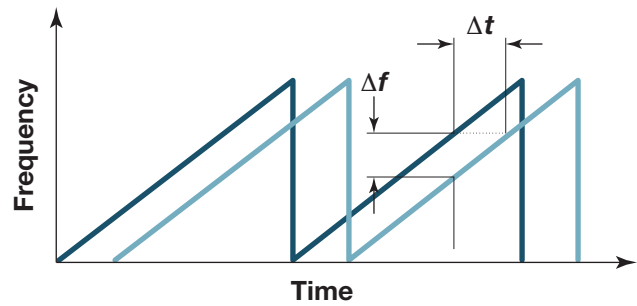

Figure 1

conversion. The main advantage of FMCW is that it utilizes higher receiving sensitivity and higher-strength signals over pulse systems, allowing it to perform better in difficult situations where there may be turbulence, foam or excessive vapors.

OPERATIONAL CONSIDERATIONS

All radar applications, regardless of the operating frequency, are characterized by three basic conditions:

- Dielectric (process medium)
- Distance (measuring range)
- Disturbances (factors such as turbulence, foam, false targets, multiple reflections, etc.)

The Pulsar Model R80 Radar transmitter is offered with several horn antenna sizes and configurations:

- ¾" NPT (G 3/4)
- 1½" NPT (G 1 1/2)
- 2" (DN 50)
- 3" (DN 80)

Since larger horns yield stronger signals and smaller beam angles, the 3" (DN 80) horn antenna should ideally be used to ensure the best possible performance in all operational conditions. However, as that is often impractical, other antenna sizes are available.

Maximum measuring range (distance) is measured from the sensor reference point (bottom of NPT thread, gasket face of BSP thread, or gasket face of flange) to the bottom of the tank. Refer to Figure 2.

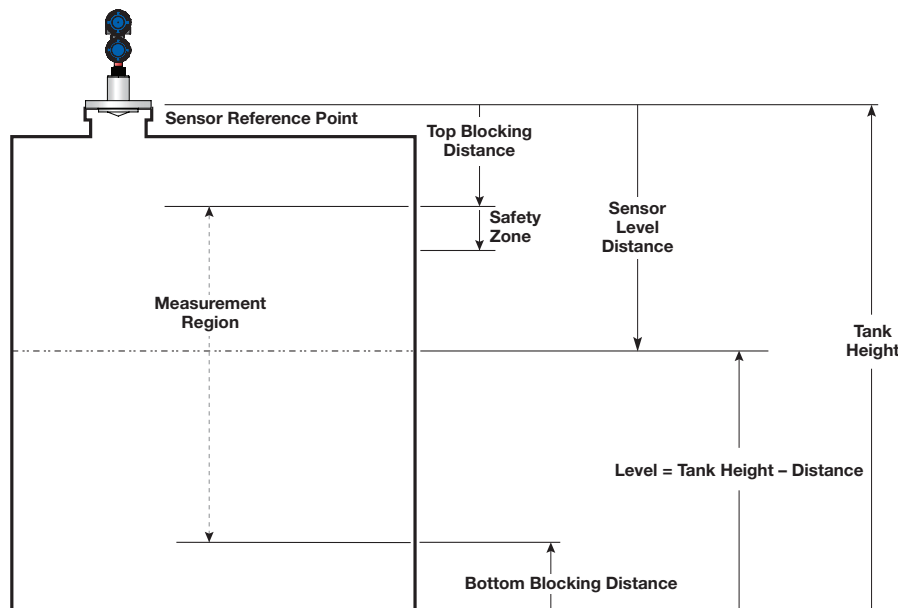

Figure 2

Figure 3 shows the maximum measuring range of each antenna size based on the dielectric and turbulence of the application. (Obstructions, noise and media buildup can drastically decrease reliable measurement.)

R80 Maximum Recommended Measuring Range in meters (feet)							
Antenna Type	Dielectric >	Turbulence None or Light			Turbulence Medium or Heavy		
		1.4 – 3	3 – 10	10 – 100	1.4 – 3	3 – 10	10 – 100
¾" Horn		4 (13)	15 (49)	25 (82)	2 (7)	7 (23)	12 (39)
1½" Horn		7 (23)	18 (59)	28 (92)	3 (10)	8 (26)	13 (43)
2" Horn		8 (26)	19 (62)	29 (95)	4 (13)	9 (30)	14 (46)
3" Horn		9 (29)	20 (65)	30 (98)	5 (17)	10 (33)	15 (49)

Figure 3

Although it is theoretically possible to measure a liquid level on the antenna, liquid should not be allowed closer than 50 mm (2 inches) from the bottom of the antenna.

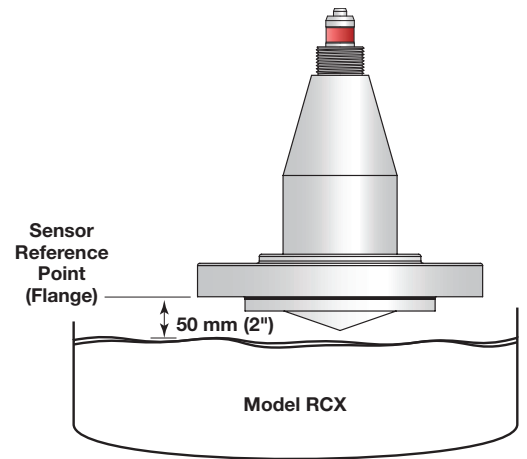

Figure 4

MOUNTING

The Pulsar Model R80 Radar transmitter can be mounted on a vessel using a variety of process connections. Generally either a threaded or flanged connection is used.

LOCATION

Ideally, the Model R80 transmitter should be mounted ½ radius from center of the tank providing an unobstructed signal path to the liquid surface where it can illuminate (with microwave energy) the largest possible surface area. Conservative recommendations are to not install in center of tank top or within 30 cm (12 inches) of tank wall. Tank walls may produce reflections that can be minimized during field configuration. Refer to Figure 5.

BEAM ANGLE

The various antenna sizes exhibit different beam patterns. Figure 7 shows the beam spread for all Pulsar Model R80 antennas. Ideally the beam pattern should illuminate the maximum liquid surface with minimum striking of other objects in the vessel including the tank wall. Use these drawings to determine the optimum installation location.

OBSTRUCTIONS

Almost any object that falls within the beam pattern can cause reflections that may be misinterpreted as a false liquid level. All possible precautions should be taken to minimize false target reflections with proper installation location. Refer to Figures 6 & 7.

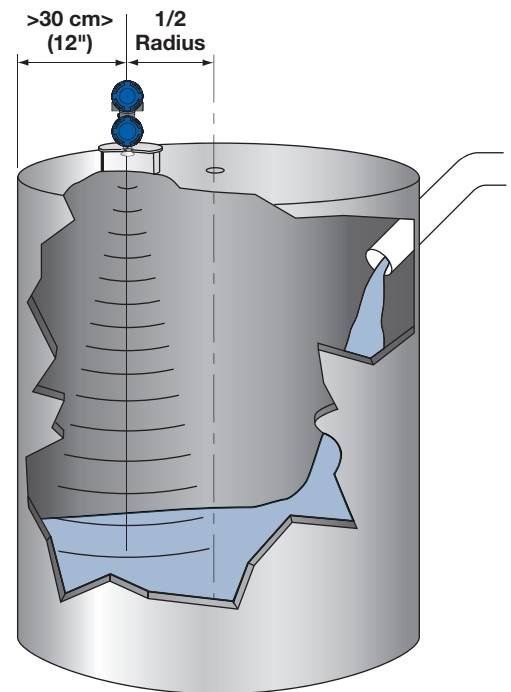

Figure 5

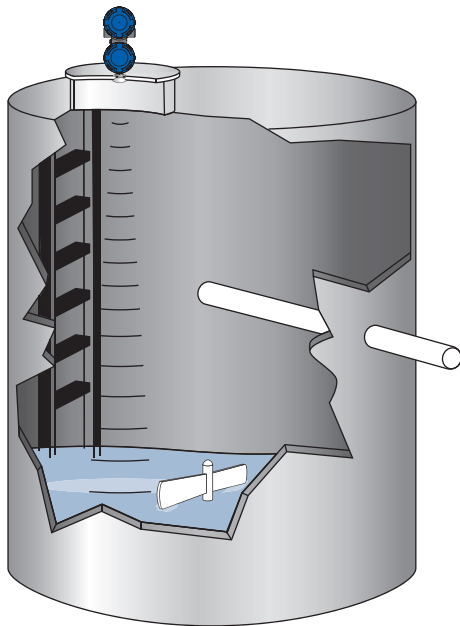
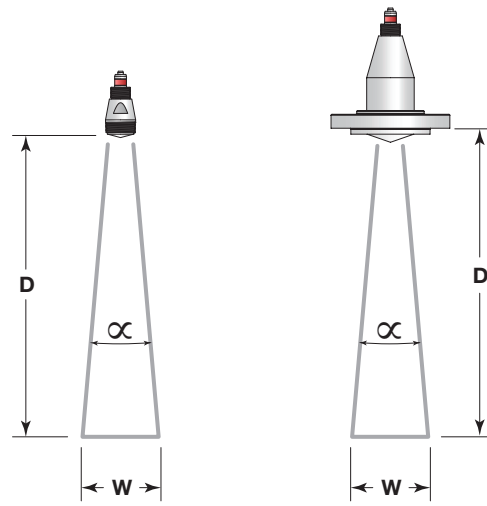

Figure 6



meters (feet)

Antenna Beam Angle (α)	Beam Spread, W @-3dB; ft (m)			
	¾" Horn 13°	1½" Horn 7°	2" Horn 6°	3" Horn 4°
Distance, D				
3 (10)	0.7 (2.3)	0.4 (1.2)	0.3 (1.1)	0.2 (0.7)
6 (20)	1.4 (4.6)	0.8 (2.5)	0.6 (2.1)	0.4 (1.4)
9 (30)	2.1 (6.9)	1.1 (3.7)	1.0 (3.2)	0.6 (2.1)
12 (40)	2.8 (9.2)	1.5 (4.9)	1.3 (4.2)	0.8 (2.8)
15 (50)	3.5 (11.5)	1.9 (6.1)	1.6 (5.3)	1.0 (3.5)
23 (75)	5.3 (17.3)	2.8 (9.2)	2.4 (7.9)	1.6 (5.2)
30 (100)	7.0 (23.1)	3.7 (12.3)	3.2 (10.5)	2.1 (7.0)

Figure 7

MOUNTING

NOZZLES

Improper installation in a nozzle can create “ringing” (undesired signals) which can adversely affect level measurement. Be sure to include any nozzle dimension that may extend down inside the vessel. Refer to Figure 8. (As this dimension is application-dependent, please consult factory in cases where this suggestion cannot be met.)

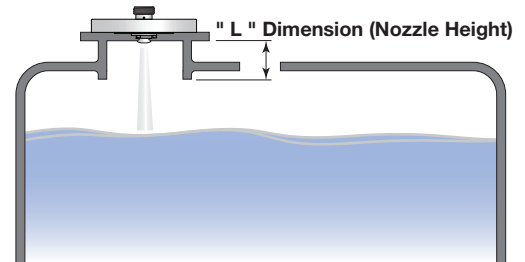
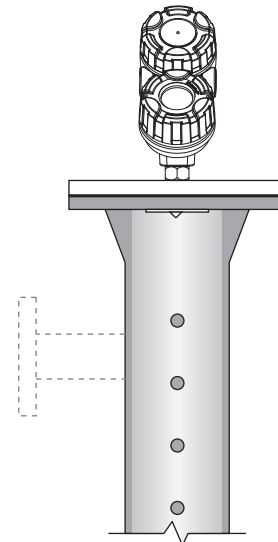

Figure 8

STANDPIPES AND STILLWELLS

The Pulsar Model R80 can be mounted in a standpipe or stillwell but certain items must be considered:

- Metal stillwells only: Inside diameter 100 mm (4 inches).
- Diameter must be consistent throughout length; no reducers or gaps.
- Use only horn antennas sized to pipe ID; 20–100mm (¾–4"); 4-inch pipe can use 3-inch horn.
- Stillwell length must cover complete range of measurement (i.e., liquid must be in stillwell).
- Welds should be smooth.
- Vents: holes <3 mm (0.125") diameter, slots <3 mm (0.125") width.
- If an isolation valve is used, it must be a full port ball valve with an I.D. equal to the pipe diameter.
- Configuration must include a non-zero entry for PIPE I.D parameter.



APPLICATIONS

FMCW RADAR

STORAGE AND INTERMEDIATE HOLDING TANKS

CONDITIONS – Calm Surfaces

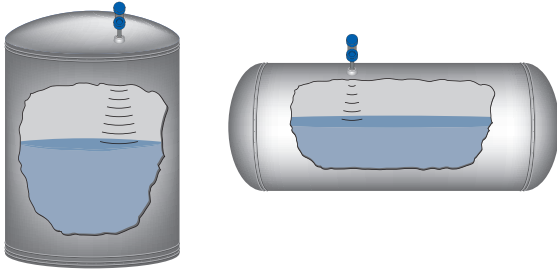

REACTORS

CONDITIONS – Turbulence and Foam

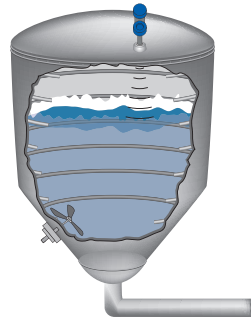

CHAMBERS AND BYPASS

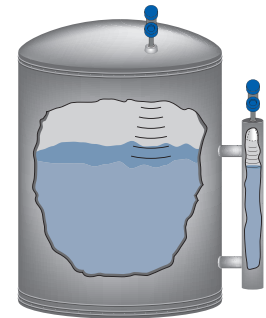

ENCLOSED SUMPS

CONDITIONS – Turbulence, Foam, and Changing Dielectric

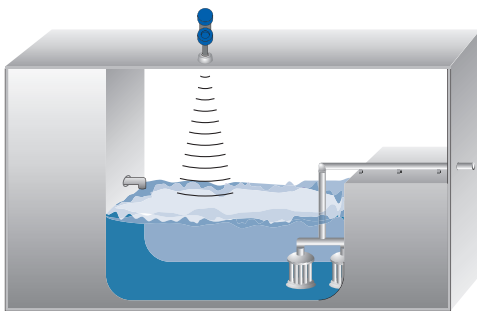

MIXING AND BLENDING VESSELS

CONDITIONS – Turbulence, Foam, and Changing Dielectric

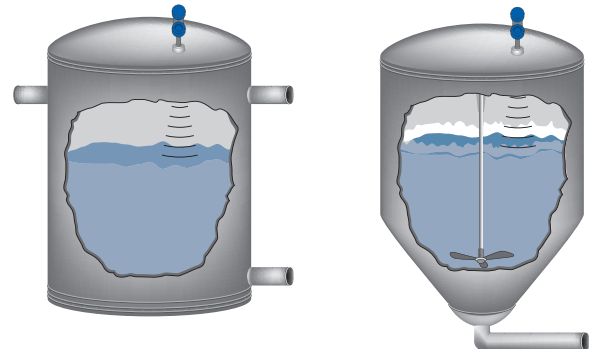

OPEN CHANNEL FLOW APPLICATIONS

$$Q=K(L-CH)H^n$$

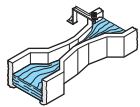

Extensive Selection of Primary Flow Elements

With a total of 35 flume and weir curves stored in the electronics, it would be hard to find an open channel flow application that cannot be handled by the R80 transmitter. Unusual flow applications can readily be accomplished through the use of either the 20-point Custom Table or the Generic Discharge Flow Equation which allows a direct entry of unique flow equations.

Dual Flow Totalizers

Two 7-digit flow totalizers are provided for recording flow in cubic feet, gallons, million gallons, liters, million liters, or cubic meters. One totalizer is resettable and the other is non-resettable. Several multipliers are selectable to allow for proper scaling. Totalizer time is also recorded to show how long each totalizer has been recording flow.

ENCLOSED FLUMES AND WEIRS

CONDITIONS – Turbulence and Changing Dielectric

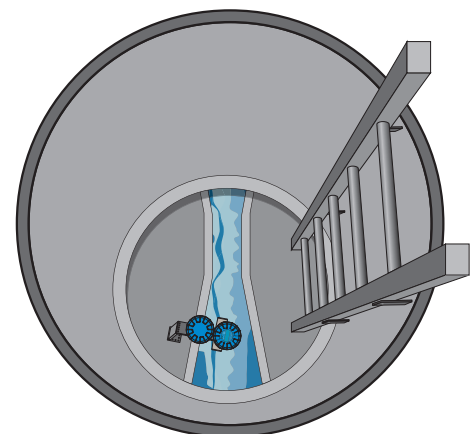

NOTE: For optimal accuracy, mount the transmitter a minimum of 25 cm (10") above the flow element (this is dependent on type and size of the flow element). Consult factory for assistance on this dimension.

TEMPERATURE / PRESSURE

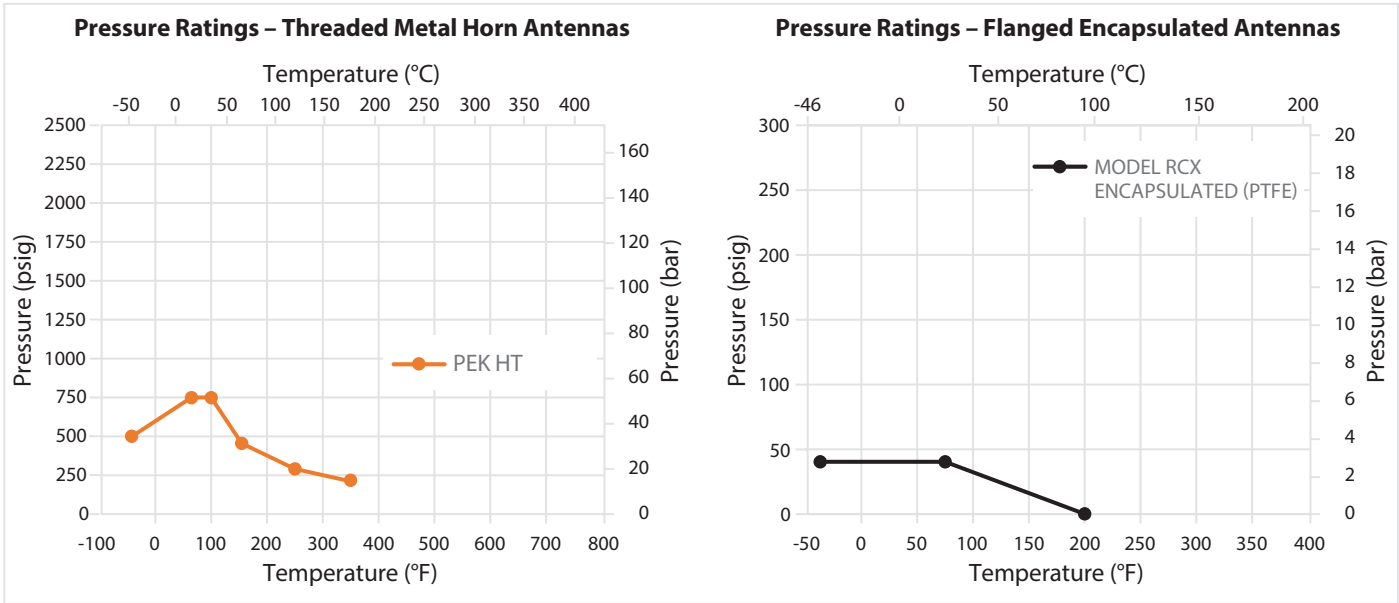

Part Number	Horn Size	Lens Thickness	Lens Material	FM Design Pressure Rating	Maximum Pressure of Proof Test	20% of Proof Test	10% of Proof Test
RC2-4500-10N-00-000	2"	4 mm (0.16")	PTFE	4.8 bar (70 psi)	48.3 bar (700 psi)	9.7 bar (140 psi)	4.8 bar (70 psi)
RC2-4500-20N-00-000	2"	8 mm (0.31")	PTFE	27.6 bar (400 psi)	172.4 bar (2500 psi)	34.5 bar (500 psi)	17.2 bar (250 psi)
RC3-5500-10N-00-000	3"	4 mm (0.16")	PTFE	4.8 bar (70 psi)	41.4 bar (600 psi)	8.3 bar (120 psi)	4.1 bar (60 psi)
RC3-5500-20N-00-000	3"	8 mm (0.31")	PTFE	27.6 bar (400 psi)	96.5 bar (1400 psi)	19.3 bar (280 psi)	9.7 bar (140 psi)

OPERATING TEMPERATURE RANGE

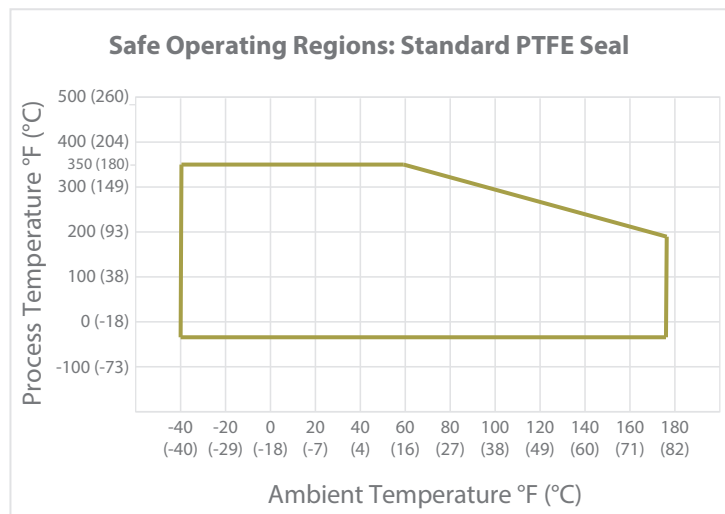

AGENCY APPROVALS



These devices are in compliance with the RED-directive 2014/53/EU, the EMC directive 2014/30/EU, the PED-directive 2014/68/EU, the ATEX directive 2014/34/EU and RoHS directive 2011/65/EU.

MAGNETROL
705 ENTERPRISE ST AURORA, 60504 IL USA

PULSAR
MODEL:
SERIAL:

AMETEK

FM21ATEX0058X / FM21UKEX0191X
II 1/2 G Ex ia/db IIB + H2 T4...T3 Gb/Gb
II 2 G Ex db ia IIB + H2 T4...T3 Gb
Ta = -40°C to +70°C
IP67

IECEX FMG 21.0012X
Ex ia/db IIB + H2 T4...T3 Gb/Gb
Ex db ia IIB + H2 T4...T3 Gb
Ta = -40°C to +70°C
IP67

MANF YEAR:
INPUT: Um=36V
OUTPUT: 4-20mA
THREADED ENTRY:
MAX PRESS:
REFER TO INSTRUCTION MANUAL

FOR US/CANADA DIVISIONS: INSTALL SEAL WITHIN 18 INCHES / UN SCELLEMENT DOIT ETRE INSTALLE A MOINS DE 18 INCHES DU BOTTIER
FOR CANADA ZONES: INSTALL SEAL WITHIN 50MM / UN SCELLEMENT DOIT ETRE INSTALLE A MOINS DE 50 MM DU BOTTIER

Explosion/Flame Proof - Intrinsically Safe

MAGNETROL
705 ENTERPRISE ST AURORA, 60504 IL USA

PULSAR
MODEL:
SERIAL:

AMETEK

FM21US0091X / FM21CA0059X
CL I, II, III, DIV 1, GP A,B,C,D,E,F,G T4...T3
CL I, ZONE 2 AEx/Ex ia IIC T4...T3 Gc
CL I, ZONE 2 AEx/Ex ic IIC T4...T3 Gc
Ta = -40°C to +70°C
TYPE 4X, IP67

FM21ATEX0058X / FM21UKEX0191X
II 1 G Ex ia IIC T4...T3 Gc
Ta = -40°C to +70°C
IP67

IECEX FMG 21.0012X
Ex ia IIC T4...T3 Gc
Ex ic IIC T4...T3 Gc
Ta = -40°C to +70°C
IP67

MANF YEAR:
THREADED ENTRY:
MAX PRESS:
REFER TO INSTRUCTION MANUAL

ENTITY
Ui(Vmax)=28.6V li(Imax)=140mA
Pi=1W Ci=4.4nF Li=2.7uH

Intrinsically Safe

MAGNETROL
705 ENTERPRISE ST AURORA, 60504 IL USA

PULSAR
MODEL:
SERIAL:

AMETEK

DIP-IS
FM21US0091X / FM21CA0059X
CL II, III, DIV 1, GP E,F,G T4...T3
Ta = -15°C to +70°C
TYPE 4X, IP67

FM21ATEX0058X / FM21UKEX0191X
II 2 D Ex ia tb IIIC T100°C Db
Ta = -15°C to +70°C
IP67

IECEX FMG 21.0012X
Ex ia tb IIIC T100°C Db
Ta = -15°C to +70°C
IP67

MANF YEAR:
INPUT: Um=36V
OUTPUT: 4-20mA
THREADED ENTRY:
MAX PRESS:
REFER TO INSTRUCTION MANUAL

FOR US/CANADA DIVISIONS: INSTALL SEAL WITHIN 18 INCHES / UN SCELLEMENT DOIT ETRE INSTALLE A MOINS DE 18 INCHES DU BOTTIER
FOR CANADA ZONES: INSTALL SEAL WITHIN 50MM / UN SCELLEMENT DOIT ETRE INSTALLE A MOINS DE 50 MM DU BOTTIER

Dust Ignition Proof

MAGNETROL
705 ENTERPRISE ST AURORA, 60504 IL USA

PULSAR
MODEL:
SERIAL:

AMETEK

FM21US0091X / FM21CA0059X
CL I, II, III, DIV 2, GP A,B,C,D,E,F,G T4...T3
CL I, ZONE 2 AEx/Ex ec IIC T4...T3
Ta = -15°C to +70°C
TYPE 4X, IP67

FM21ATEX0058X / FM21UKEX0192X
II 3 G Ex ec IIC T4...T3 Gc
II 3 G Ex ic IIC T4...T3 Gc
IP67

IECEX FMG 21.0012X
Ex ec IIC T4...T3 Gc
IP67

MANF YEAR:
INPUT: Um=36V
OUTPUT: 4-20mA
THREADED ENTRY:
MAX PRESS:
REFER TO INSTRUCTION MANUAL

Non-Incendive, Increased Safety

Telecommunications Approvals

Agency	In-Tank	Out of Tank
FCC	47 CFR, Part 15, Subpart C, Section 15.209 Unintentional Radiators	47 CFR, Part 15, Subpart C, Section 15.256
ISED	RSS-211	RSS-211
ETSI	EN 302 372 V2.1.1 (2016-12)	EN 302 729 V2.1.1 (2016-12)

FCC/ISED TLPR Use Configurations for Enclosed Tank Applications Only

Antenna Type	Frequency band (GHz)	Reinforced Fiberglass Tank	Concrete Tank	Metal Tank
3/4"	77 to 81	Allowed	Allowed	Allowed
1 1/2"	77 to 81	Allowed	Allowed	Allowed
2"	77 to 81	Allowed	Allowed	Allowed
3"	77 to 81	Allowed	Allowed	Allowed

FCC/ISED LPR Use Configurations

Antenna Type	Frequency band (GHz)	Open Air / Tank
2"	77 to 81	Allowed
3"	77 to 81	Allowed

TRANSMITTER SPECIFICATIONS

FUNCTIONAL/PHYSICAL

System Design

Measurement Principle	Frequency Modulated Continuous Wave (FMCW) Radar 80 GHz
-----------------------	---

Input

Measured Variable	Level, determined by the difference in modulated frequencies
Span	0.2 to 30 meters (0.5 to 100 feet)

Output

Type	4 to 20 mA with HART: 3.8 mA to 20.5 mA useable (per NAMUR NE43)
Resolution	Analog: .003 mA / Digital Display: 1 mm
Loop Resistance	GP/IS: 590 ohms @ 24 VDC and 22 mA XP/Flameproof: 500 ohms @ 24 VDC and 22 mA
Diagnostic Alarm	Selectable: 3.6 mA, 22 mA (meets requirements of NAMUR NE 43), or HOLD last output
Diagnostic Indication	Meets requirements of NAMUR NE107
Damping	Adjustable 0–10 seconds

User Interface

Keypad	4-button menu-driven data entry
Display	Graphic Liquid Crystal Display
Digital Communication	HART ver. 7–w/ Field Communicator; AMS, or FDT DTM (PACT ^{ware} ™), FDI/EDDL
Menu Languages	Transmitter LCD: English, French, German, Spanish, Russian, Portuguese, Polish HART DD: English, French, German, Spanish, Russian, Chinese, Portuguese, Polish

Voltage (Measured at instrument terminals)	HART: General Purpose (Weather proof)/Intrinsically Safe/Explosion-proof: 11 VDC minimum at terminals under certain conditions (refer to Manual 58-604)
---	--

Housing

Material	IP67/die-cast aluminum A413 (<0.6% copper); optional stainless steel
Net/Gross Weight	Aluminum: 2.0 kg (4.5 lbs.) / Stainless Steel: 4.50 kg (10.0 lbs.)
Cable Entry	½" NPT or M20
SIL 2 Hardware (Safety Integrity Level)	Safe Failure Fraction = 92.3% (HART only); Functional Safety to SIL 2 as 1oo1 in accordance with IEC 61508 (Full FMEDA report available upon request)

ENVIRONMENT

Ambient Operating Temperature	-40 to +160 °F (-40 to +70 °C); LCD viewable -20 to +70 °C (-5 to +160 °F)
Storage Temperature	-45 to +85 °C (-50 to +185 °F)
Humidity	0–99%, non-condensing
Electromagnetic Compatibility	Meets CE requirement (EN 61326) and NAMUR NE 21
Surge Protection	Meets CE EN 61326 (1000V)
Shock/Vibration	ANSI/ISA-S71.03 Class SA1 (Shock); ANSI/ISA-S71.03 Class VC2 (Vibration)

PERFORMANCE

Reference Conditions	Reflection from ideal reflector at +20 °C (+70 °F)
Linearity	≤ 1mm
Measured Error	≤ 1mm (Performance will degrade slightly within 25 cm (10") of antenna)
Resolution	0.1 inch or 1mm
Repeatability	≤ 1mm
Response Time	< 3 seconds (configuration dependent)
Initialization Time	< 30 seconds (configuration dependent)
Ambient Temperature Effect	Digital < 3 mm/10 K, 10 mm maximum Analog < 0.03 %/10 K or 0.3 % maximum relating to the 16.7 mA span)
Maximum Rate of Change	450 cm (180 inches)/minute

ANTENNA SPECIFICATIONS

FUNCTIONAL / PHYSICAL

Antenna Material	316 SS, PEEK, PTFE
Process Seal Material	PTFE, PEEK with O-rings
Maximum Process Temperature	Up to +204 °C @ 94.8 bar (+400 °F @ 1375 psi)
Maximum Process Pressure	PEEK with O-rings: -1.0 to 70 bar @ +20 °C (-14.7 to 1000 psi @ +70 °F) 4mm PTFE lens: -1.0 to 14 bar @ +20 °C (-14.7 to 200 psi @ +70 °F) 8mm PTFE lens: -1.0 to 27 bar @ +20 °C (-14.7 to 400 psi @ +70 °F)
Vacuum Service	Hermeticity to $<5 \times 10^{-7}$ cc/sec helium
Minimum Dielectric (application dependent)	1.7 (1.4 with stillwells)

DIMENSIONAL SPECIFICATIONS

MM (INCHES)

Transmitter

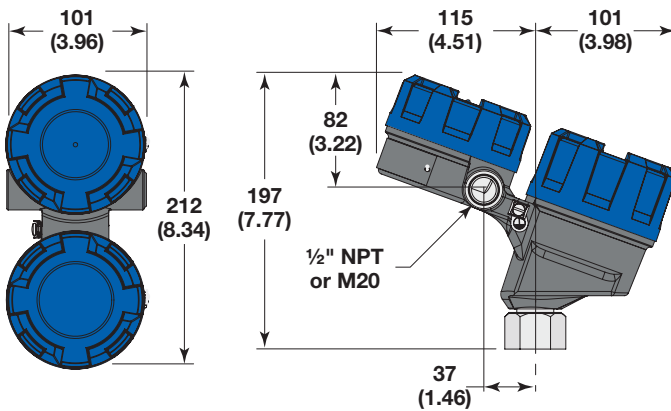

Threaded Metal Antennas

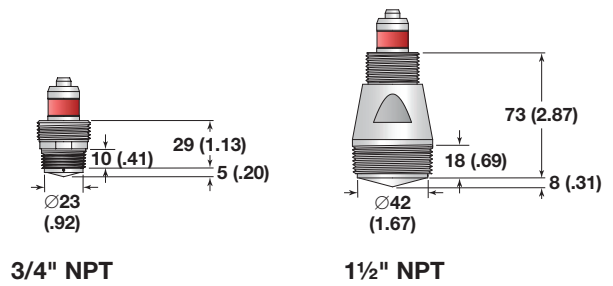

Flanged Encapsulated Antennas

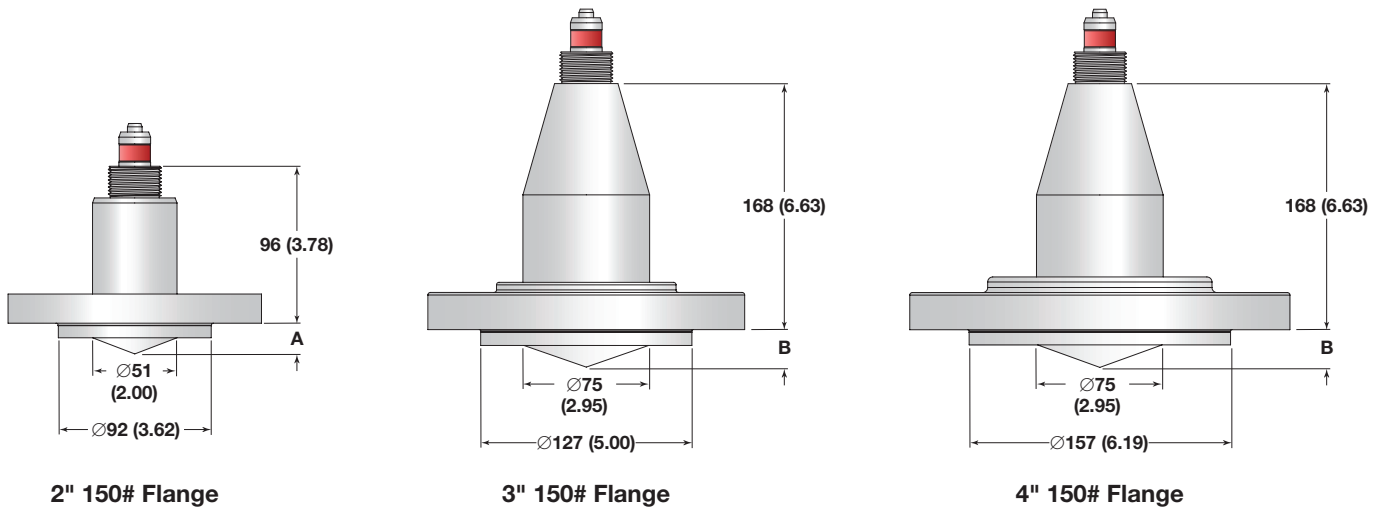

	A	B
4 mm (0.16") Lens	.54 (14)	.69 (18)
8 mm (0.31") Lens	.70 (18)	.83 (21)

TRANSMITTER MODEL NUMBER

1-3 | MEASUREMENT SYSTEM

R 8 0	Through-Air Radar Level Transmitter - 80 GHz FMCW Radar
-------	---

4 | POWER

5	24 VDC, Two Wire
---	------------------

5 | SIGNAL OUTPUT

1	4-20 mA with HART
---	-------------------

6 | SAFETY OPTIONS

1	SIL 2 Hardware
---	----------------

7 | ACCESSORIES/MOUNTING

0	No Digital Display and Keypad
A	Digital Display and Keypad

8 | CLASSIFICATION

0	General Purpose, Weatherproof (IP 67)
1	Intrinsically Safe
3	Explosion-proof/Flameproof (with IS antenna)
C	Non-Incendive, Increased Safety
D	Dust Ignition-proof / Protection by Enclosure

9 | HOUSING

1	Die-cast Aluminum, Dual Compartment, 20-degree
2	Investment Cast, 316ss, Dual Compartment, 20-degree

10 | CONDUIT CONNECTION

0	½" NPT
1	M20
2	½" NPT with sunshade
3	M20 with sunshade

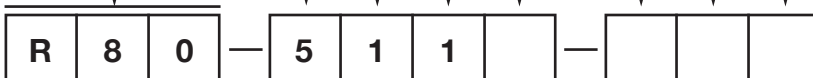

ANTENNA MODEL NUMBER

1-2 | TECHNOLOGY

R C	Pulsar Radar Antennas - 80 GHz
-----	--------------------------------

3 | CONFIGURATION/STYLE

0	¾" Horn
1	1½" Horn
2	2" Horn ①
3	3" Horn ①

4-5 | PROCESS CONNECTION - SIZE/TYPE

11	¾" NPT	31	1½" NPT thread
----	--------	----	----------------

ASME Flanges

43	2" 150# ASME raised face flange	DA	DN 50, PN 16	EN 1092-1 Type A
44	2" 300# ASME raised face flange	DB	DN 50, PN 25/40	EN 1092-1 Type A
45	2" 600# ASME raised face flange	DD	DN 50, PN 63	EN 1092-1 Type B2
53	3" 150# ASME raised face flange	DW	DN 50, PN 16	EN 1092-1 Type B1
54	3" 300# ASME raised face flange	DZ	DN 50, PN 25/40	EN 1092-1 Type B1
55	3" 600# ASME raised face flange	EA	DN 80, PN 16	EN 1092-1 Type A
63	4" 150# ASME raised face flange	EB	DN 80, PN 25/40	EN 1092-1 Type A
64	4" 300# ASME raised face flange	ED	DN 80, PN 63	EN 1092-1 Type B2
65	4" 600# ASME raised face flange	EW	DN 80, PN 16	EN 1092-1 Type B1
		EZ	DN 80, PN 25/40	EN 1092-1 Type B1
		FA	DN 100, PN16	EN 1092-1 Type A
		FB	DN 100, PN 25/40	EN 1092-1 Type A
		FD	DN 100, PN 63	EN 1092-1 Type B2
		FW	DN 100, PN 16	EN 1092-1 Type B1
		FZ	DN 100, PN 25/40	EN 1092-1 Type B1

EN (DIN) Flanges

6 | CONSTRUCTION CODES

0	Industrial
K	ASME B31.1
L	ASME B31.3
M	ASME B31.3 & NACE MR0175 / MR0103
N	NACE MR0175 / MR0103

8 | MATERIAL OF CONSTRUCTION - WETTED SURFACES

A	316SS/316L SS
1	PTFE Faced Flange: 4mm (0.16") thick ②
2	PTFE Faced Flange: 8mm (0.31") thick ②

10 | O-RING MATERIALS/SEAL OPTIONS

0	Viton VX065
2	Kalrez 4079
8	Simriz SZ485 (formerly Aegis PF128) — NACE
A	Kalrez 6375
N	None

- ① 2" or 3" horn required for FCC/ETSI/ISED (Out of Tank)
 ② Must be used with 10th digit = N.

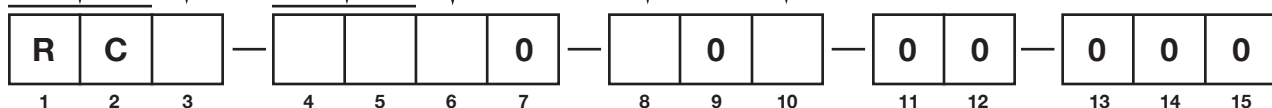

QUALITY



The quality assurance system in place at Magnetrol guarantees the highest level of quality throughout the company. Magnetrol is committed to providing full customer satisfaction both in quality products and quality service.

The Magnetrol quality assurance system is registered to ISO 9001 affirming its commitment to known international quality standards providing the strongest assurance of product/service quality available.

QUICK SHIPMENT

Several Pulsar Through-Air Radar Level Transmitters are available for quick shipment. This service may not apply to orders of ten

units or more. Contact your local representative for lead times on larger volume orders, as well as other products and options.

WARRANTY



All Magnetrol electronic level and flow controls are warranted free of defects in materials or workmanship for eighteen months from the date of original factory shipment.

If returned within the warranty period; and, upon factory inspection of the control, the cause of the claim is determined to be covered under the warranty; then, Magnetrol will repair or replace the control at no cost

to the purchaser (or owner) other than transportation.

Magnetrol shall not be liable for misapplication, labor claims, direct or consequential damage or expense arising from the installation or use of equipment. There are no other warranties expressed or implied, except special written warranties covering some Magnetrol products.



MAGNETROL[®]
AMETEK[®]

Aurora, IL USA Manufacturing Facility

705 Enterprise Street • Aurora, Illinois 60504 USA
630-969-4000 • e-mail: info.magnetrol@ametek.com

European Manufacturing Facility

Heikensstraat 6 • 9240 Zele, Belgium
+32-(0)52-45.11.11 • e-mail: info.magnetrolbe@ametek.com

Shanghai Manufacturing Facility

Plant 6, No. 191, Huajin Road Minhang District, Shanghai, China
+86-21-6249-1350 • e-mail: il-aur-rfqchina@ametek.com

Dubai, UAE Manufacturing Facility

P.O. Box 261454 – LIU FZS1-BA03, Jebel Ali Free Zone (JAFZA) • Dubai, United Arab Emirates
+971 4 8806345 • e-mail: MUAInfo@ametek.com

magnetrol.com

For additional information, see Instruction Manual 58-604.

Pulsar Radar transmitters may be protected by one or more of the following U.S. Patent Nos.:
US 6,062,095; US 6,980,174; US 7,102,584; US 7,106,248